



Kit Instructions

NKP STOCK CARS



Hi!

I'm Sarah Griessenboeck and will guide you through the assembly of the NKP stock cars. Please read this instruction manual more as a personal reference of my own experiences with the material and design. There are better modellers out there for sure and I just want to give you an insight of how I assemble this kit.

These instructions were written by Sarah in late 3/2026 and revised 4/21 to include a missing section pertaining to doors. Steps are based on how she designed and built her pilot models prior to my getting involved with sales, production, and distribution. Assembly steps are the same as outlined below but the production parts have changed drastically, primarily with the consolidation of many individual parts, including wire used for piping, into single, 3D-printed subassemblies.

***Jim King
Smoky Mountain Model Works, Inc.
4/21/2026***

Step 1 - Frame Assembly

Glue floor and frame together. I love 2K transparent epoxy glue with a setting time of five minutes. That's enough time to be able to adjust the parts and still fast enough to continue building after some 20 minutes. I do not recommend CA for the larger parts.

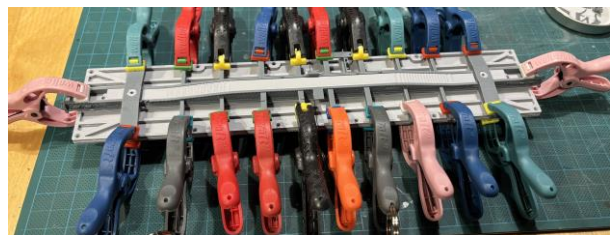
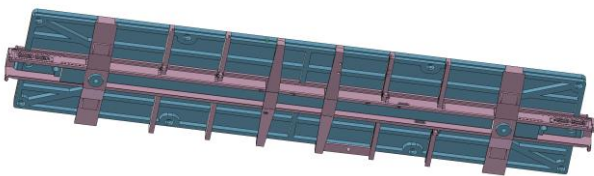

Step 2 - Air Line

The 0.032" rod material (brass or copper bronze wire) to model the air line. Make sure the ends are slightly rounded with a file. Do not force the rod into the pipe brackets. You might have to clean out the pipe brackets with a drill bit. To do that, make your own tool by filing the end of a 0.040" brass rod flat and use a power tool to clean out the parts. I do this all the time and it works really well. You can file down on the brass rod from both ends to create a sharp rotating blade.



I recommend using two rods, one for each side of the car. Carefully bend a radius for the crossing through the center sill. My floor might vary from the one that you have in your Smoky Mountain Kit, my air-line ends right where the center sill sits. Do not glue anything down yet. **Do not forget to include your T-fitting in this step.** The exact location will be dictated by the type of brake you decided to model. I like to glue the parts only when I have achieved a good fit by applying a drop of CA with a thin piece of wire. **ALLOW THE ENDS OF THE AIR LINE TO STICK OUT OVER THE END SILLS, we will cut them to length later after final assembly.**

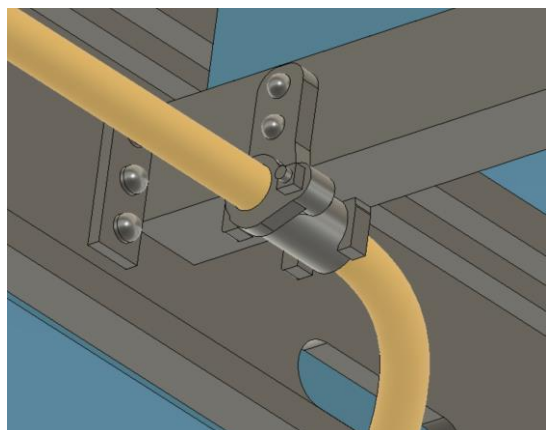

Step 3 - Brake parts

Assemble the underframe following the pictures above. Jim King has achieved a major accomplishment by printing the delicate brake parts in a very special flexible resin. I don't have the parts here while I'm putting together the instructions but you have now a very good overview of where the parts go and how the general arrangement is going to be for each type of brake system.

KC-Brake or AB-Brake?

You can choose between the two brake versions. The cars were originally built with a K-brake and often retrofitted with an AB-setup when shopped. Both brakes types were used until the end of these cars. Now it's time to decide.

KC-Brake

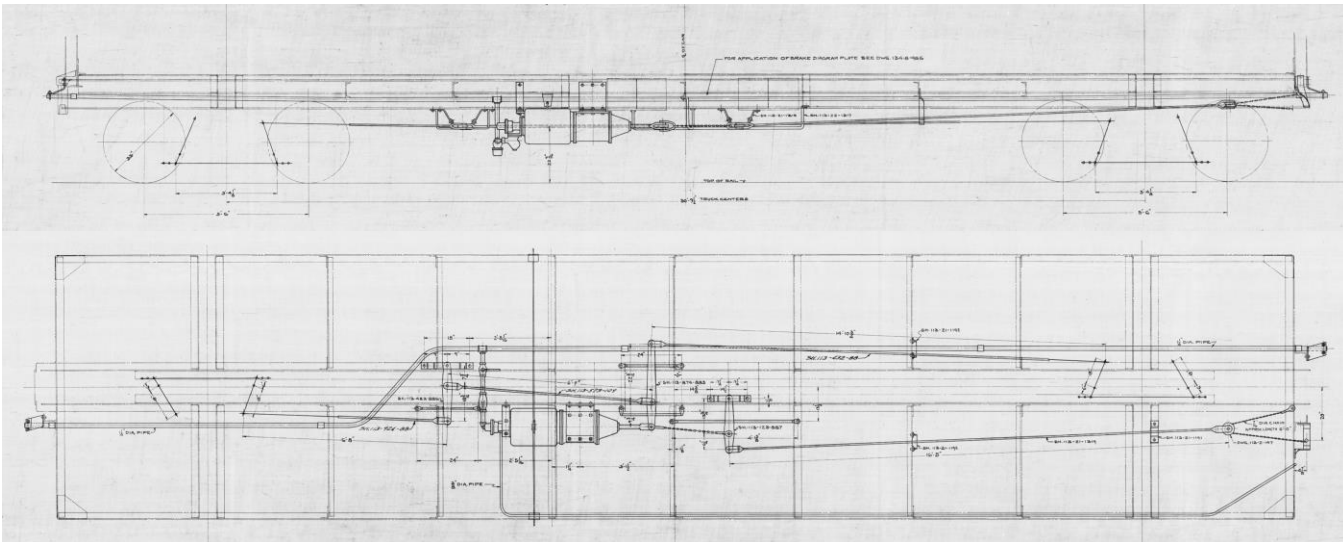

NKP frame with KC-brake

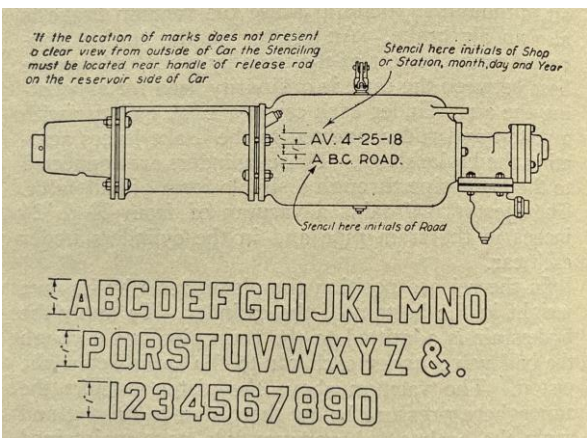

Westinghouse Single Pressure Retaining Valve

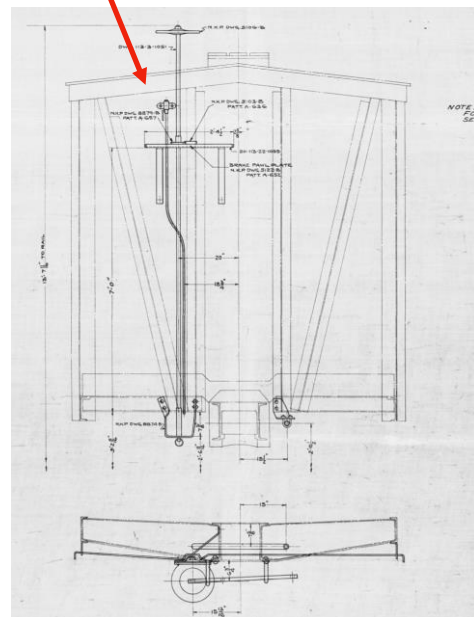
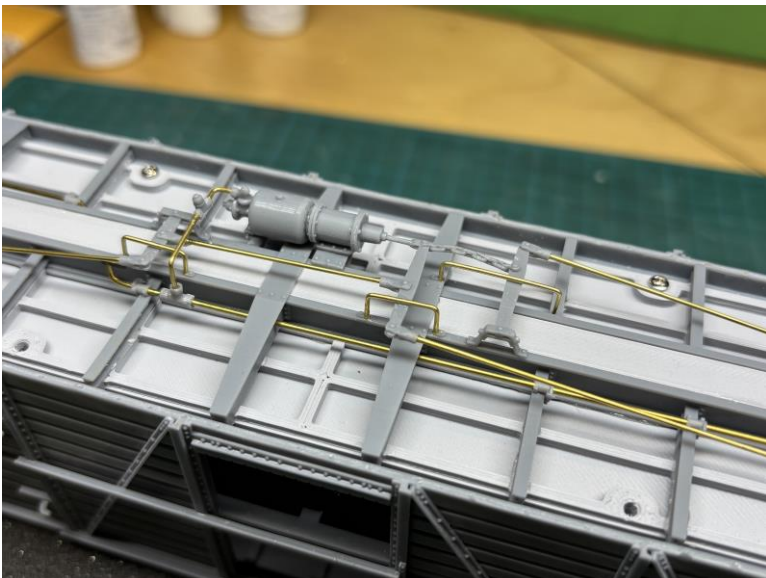
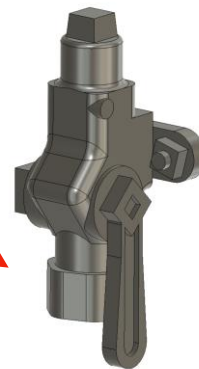

NKP frame, B-end

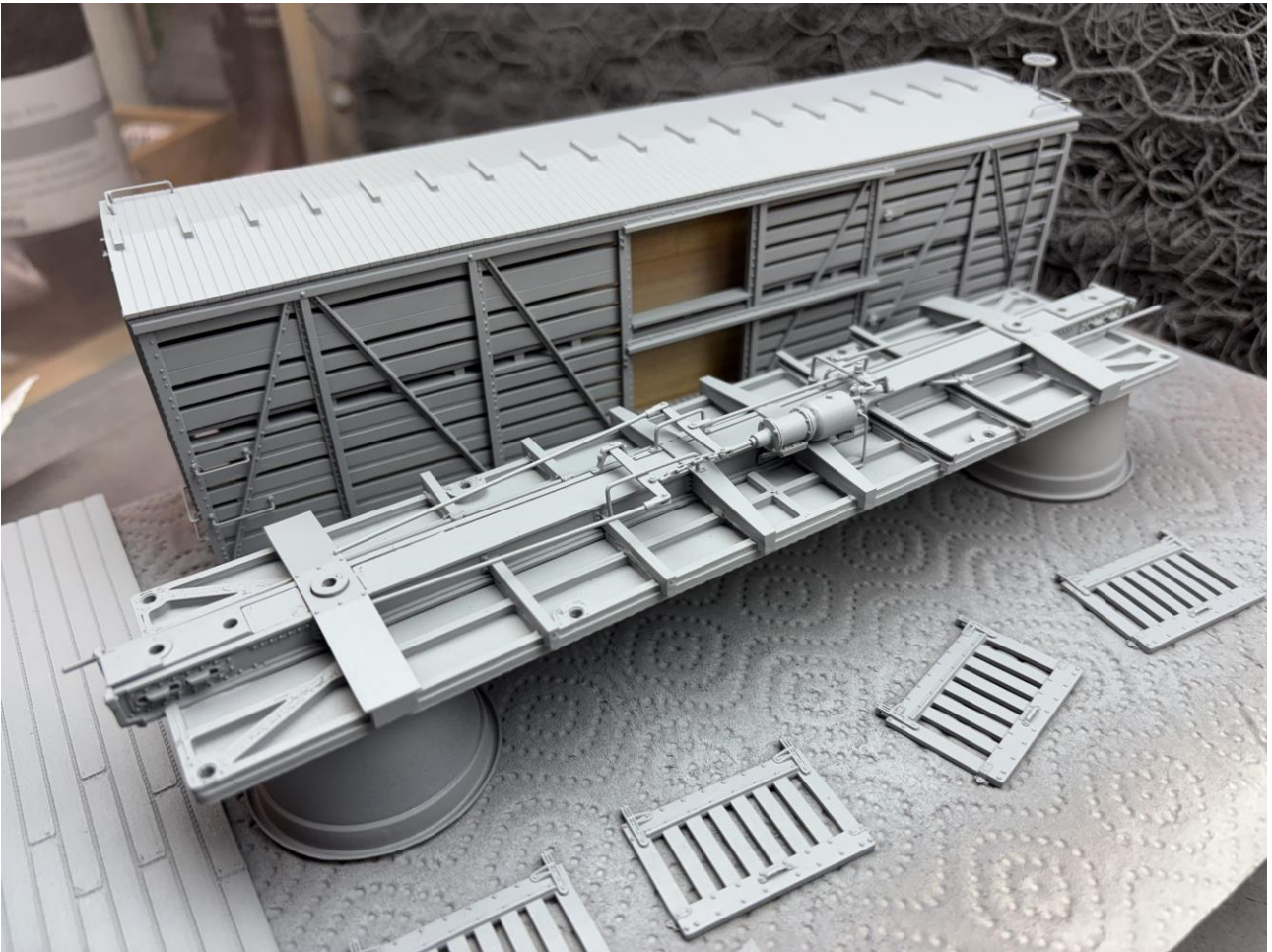

AB-Brake

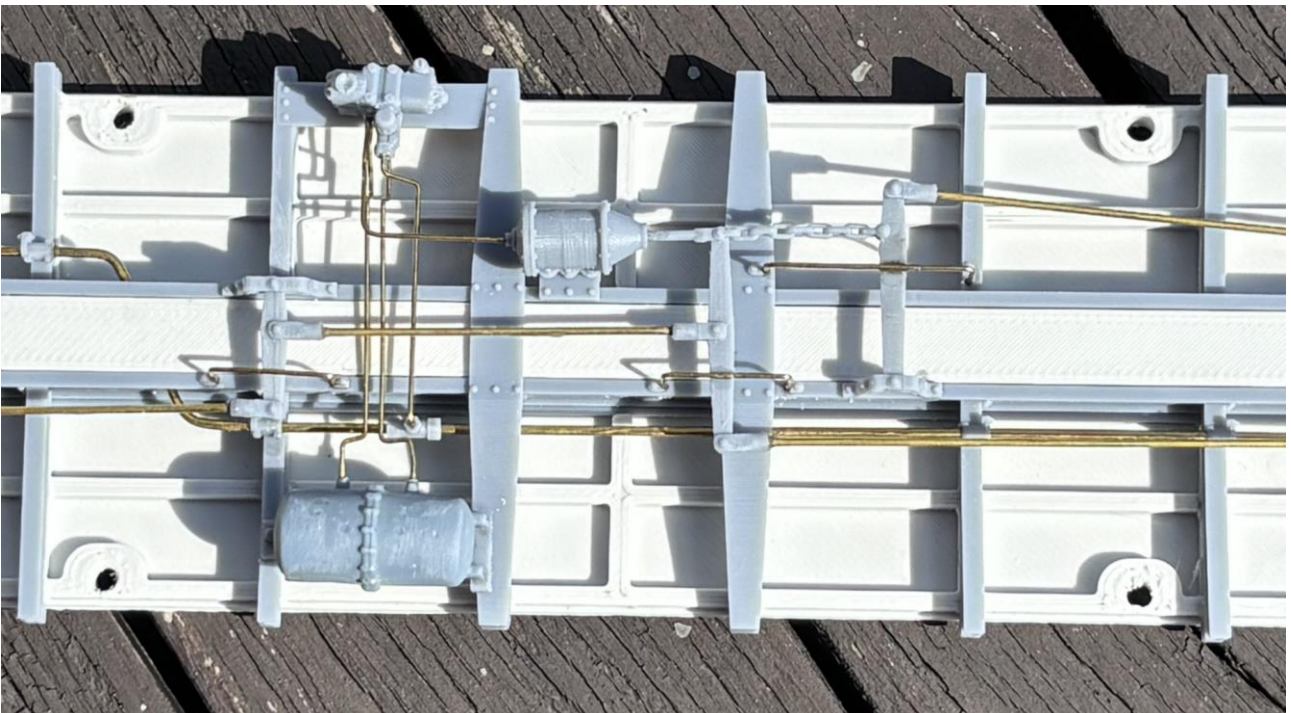

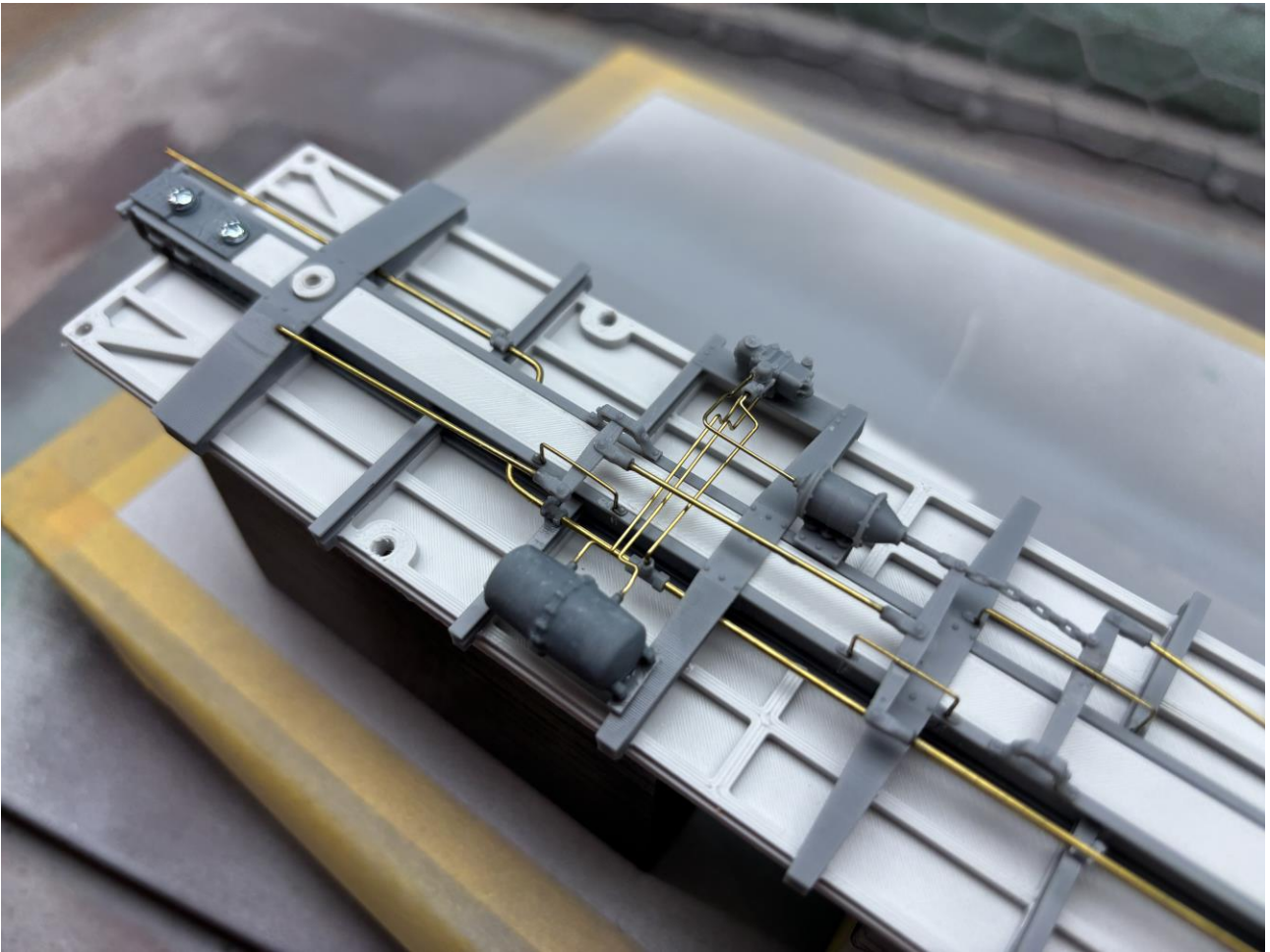

Step 4 - Coupler Installation

Both Kadee and Protocraft couplers can be used with the car. The draft gear box is relatively narrow to create a realistic model. The lateral movement of the coupler is restricted compared to a standard Kadee coupler box but sufficient to operate the relatively short car without creating problems.

Insert the coupler spring as usual. Use two round head screws to mount the coupler using the corresponding part. Do not over-tighten the screws.

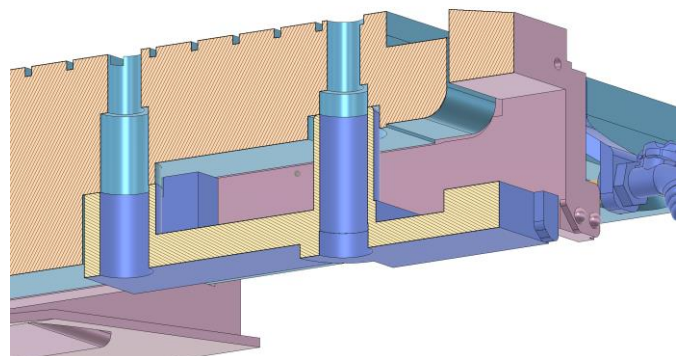
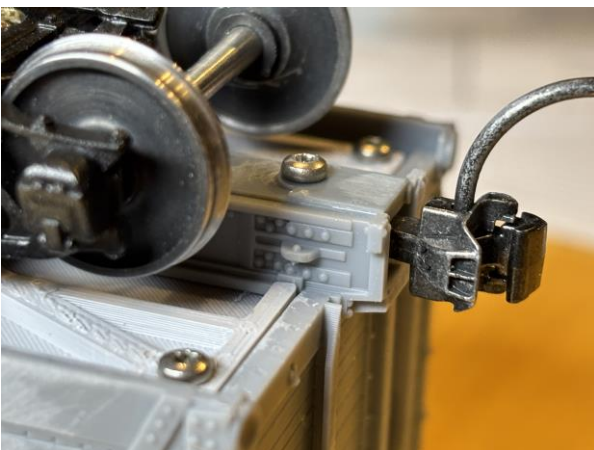
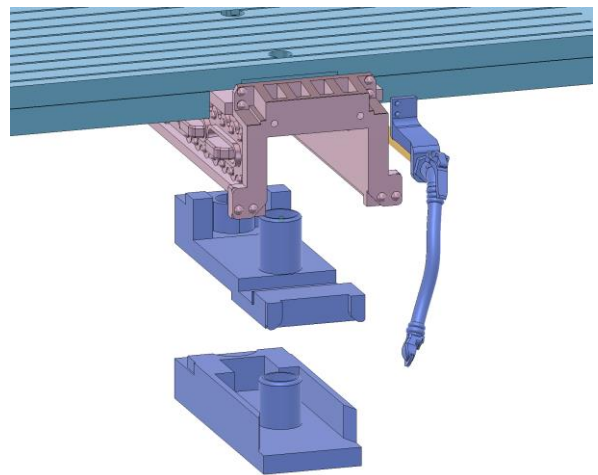

Step 5 - Body Assembly

Now it's time to glue the car ends in place. The parts should fit together nicely. Glue them together without using excessive amounts of glue to prevent spillage. It is better to come back with some glue later and work from the inside. The ends have a groove where the car body sides will fit into.

I use long rubber bands to fix the car ends together when gluing the parts. Take your time; this step is crucial.

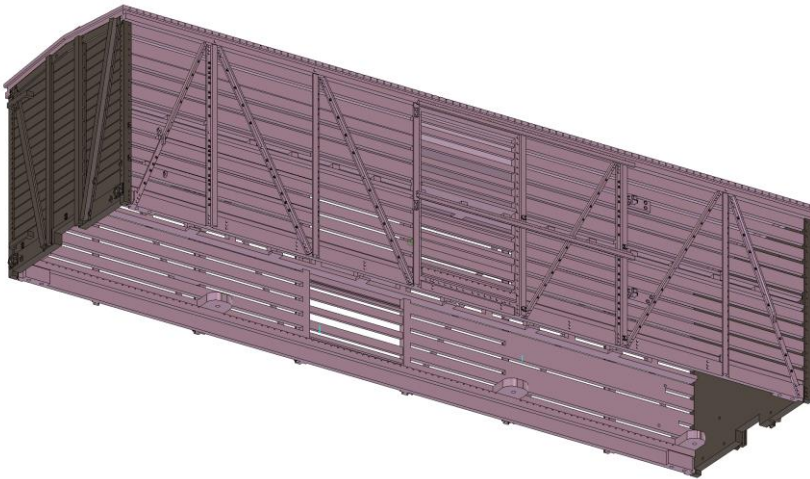

Step 6 - Body Preparation and Internal Studs

Should you find any layering lines or print artefacts that you don't like, use wet-sanding to smoothen the surface. I usually give my models a complete sand over with 250 grit wet sanding paper. Do not dry-sand to prevent dust that you should not inhale.

The single deck car has six internal studs for long term stability. The double deck car has the 2nd level floor that serves the same purpose. Glue these parts in place now or at a later stage should you wish to decorate your 2nd floor.



Step 7 - Grab Irons & Lever Brackets

Use the jig and 0.020" wire to create grab irons and brackets. Glue grabs from the inside of the car body to prevent glue spots.

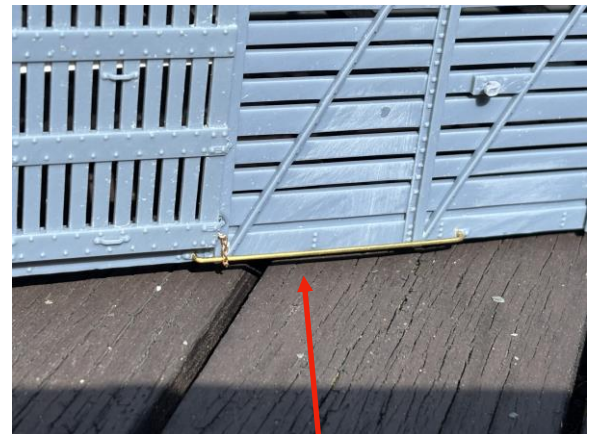
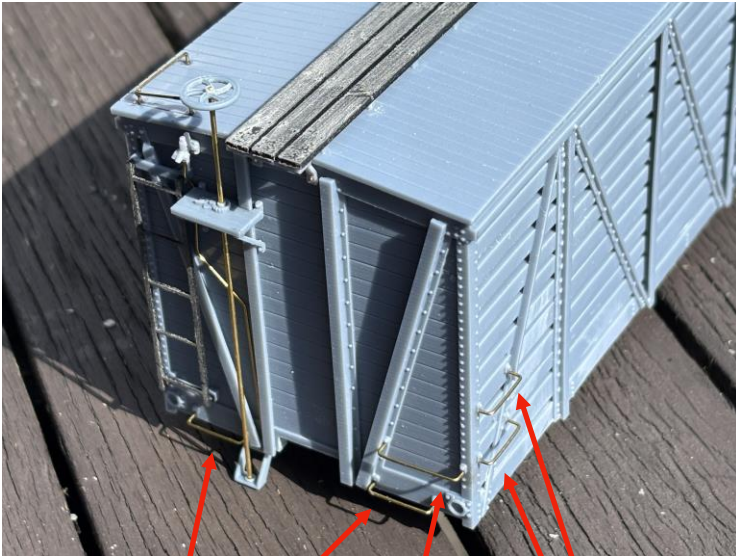

B

C

A

D

E

F

G

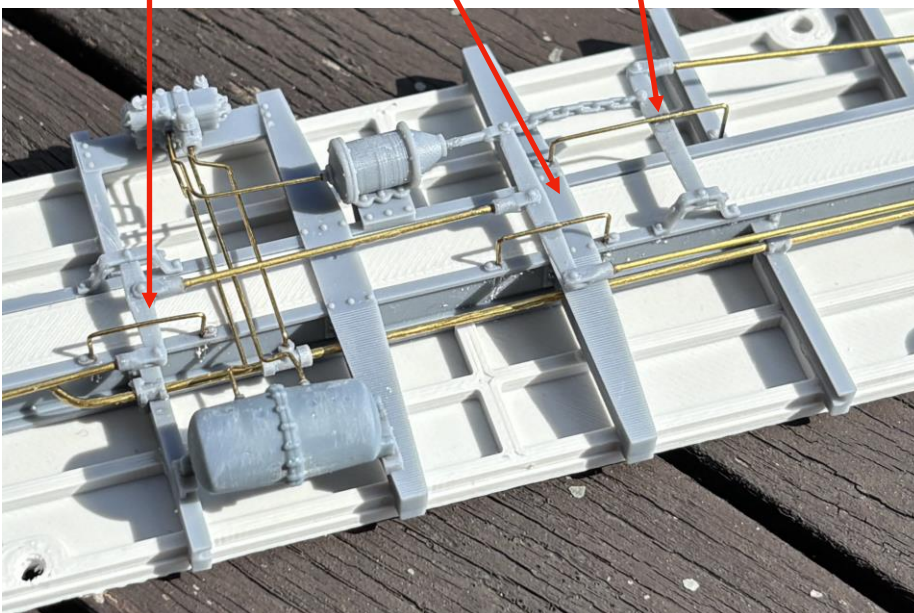

Step 8 - Running Boards and Ladders

CA glue is my choice with these parts. I personally like to secure the roof walks with 0.020" brass pins, using my mini drill. I also mount my letter boards that way but you might just want to glue them down without. (NOTE: I designed new letter boards to eliminate the need for wire and added a locating pin on the back ... align with the mating hole and attach to the body with glue. Jim King)

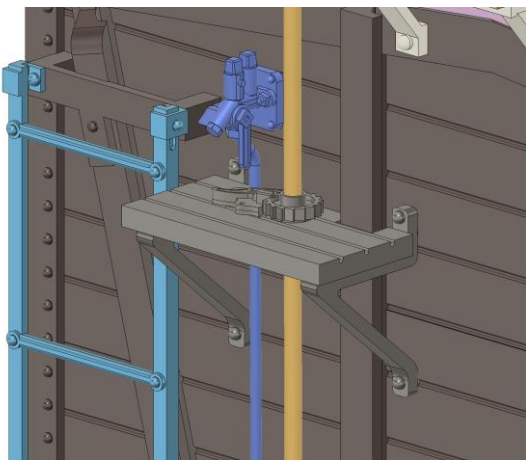
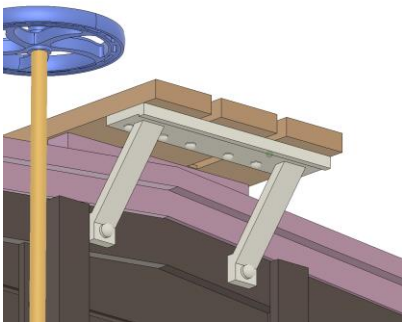
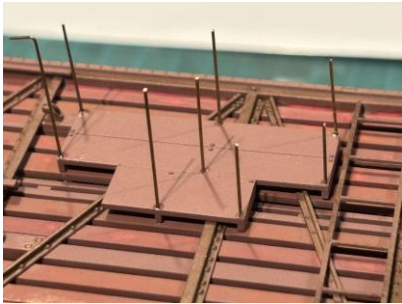

Step 9 - B-End Detail

Please note that the retaining valve of AB and KC brakes are different. KC uses the single pressure retaining valve with it's single cylinder, while the AB brake uses the double pressure one with two cylinders.

The brake rod should be modelled using a 0.030" wire. Make sure to clean out the holes in the brake step, lower bracket and brake wheel using that same sized drill bit.

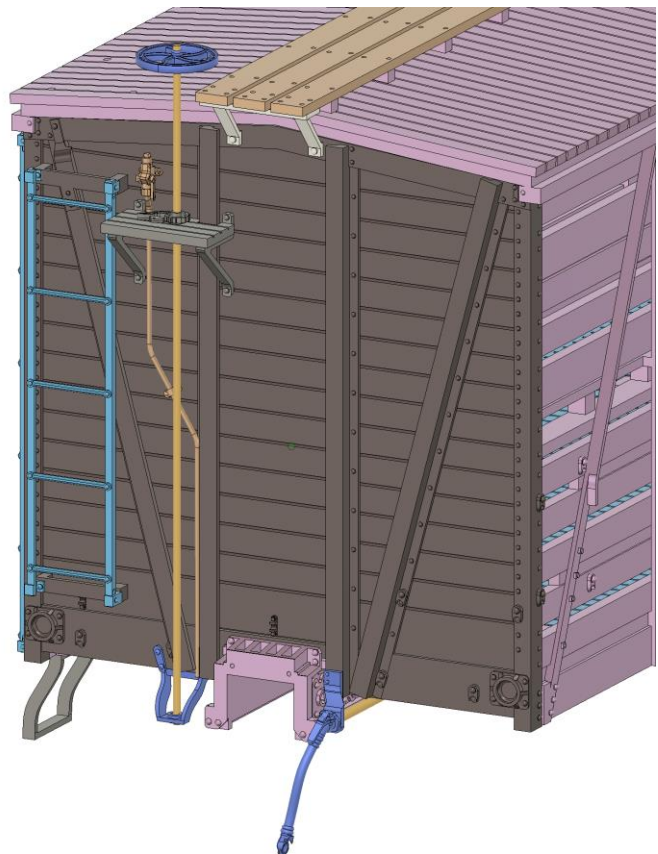

Step 10 - Doors

Install the doors. Add a little piece of chain, if you like. The doors could be displayed open, too. I recommend gluing them in place with 2k epoxy to prevent any accidents on the high iron.

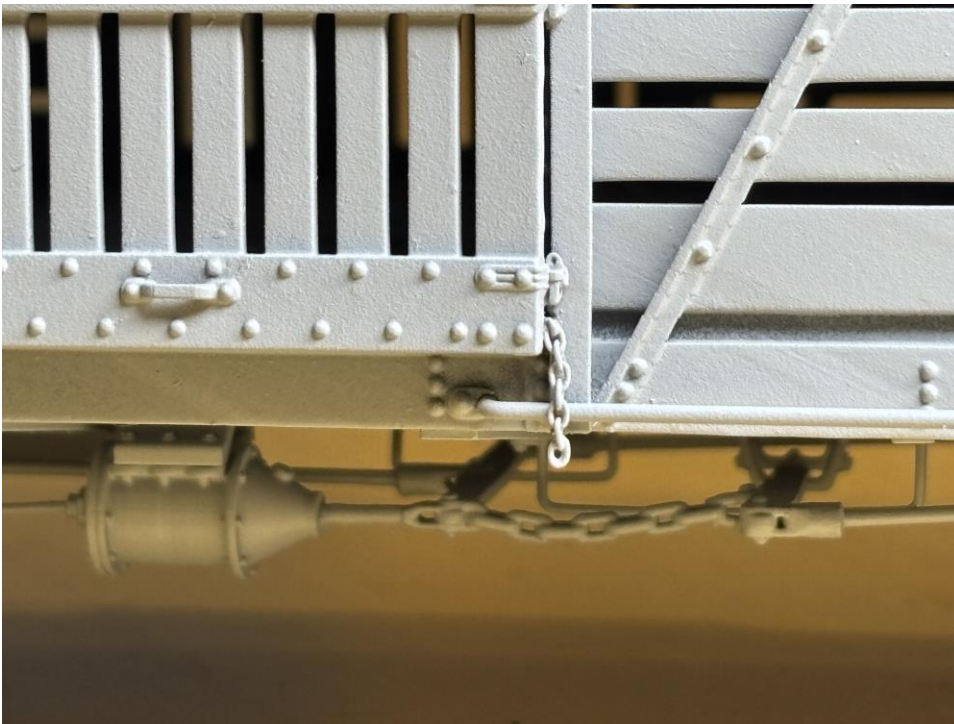

Step 11 - Painting and Lettering

I personally use Tamiya spray primer to prepare the model for painting. It is important to remove grease and dust by washing the model with some dish washing soap. Immediately before spraying primer I give the model a hose-down with compressed air to prevent dust from creating imperfections.



Step 12 - Final Assembly

The frame and car body are joined with eight flat head screws. Now it's time to finally attach air hoses (there are 2 styles in the kit).

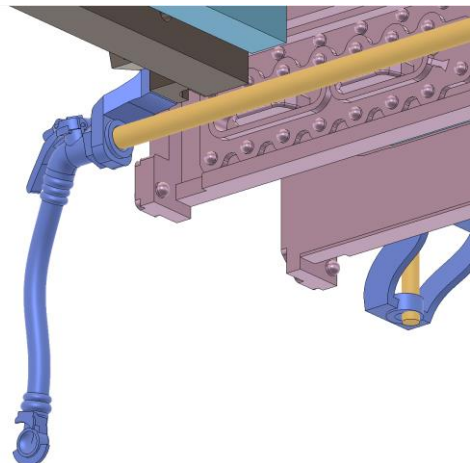

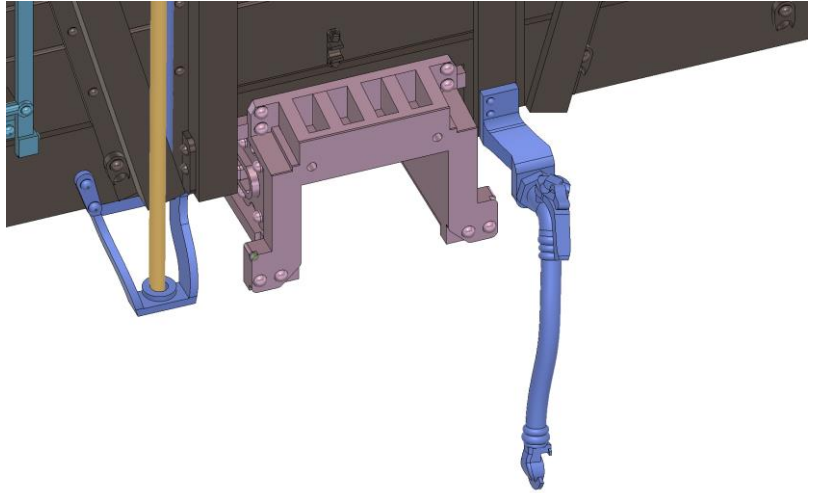

The air hoses have been printed in flexible resin and look a bit different to those in my pilot model. Pilot model steps are etched brass but kit parts are the flexible resin. Both materials are included ... you choose.



Here's a shot of the pilot model that I built. I did not have high quality decals when I built it (you can see that the film is too thick). Your decals, designed by Dr. Dave Campbell, printed by Bill Brillinger at PDC.CA, are of much higher quality. They have been designed especially for this kit.